



U-COM 7R

User manual



SUMMARY

1. ABOUT	3
1.1 Product details.....	3
1.2 Package contents	3
2. HOW TO INSTALL	4
2.1 Install main unit	4
3. GETTING STARTED	5
4. PAIRING WITH OTHER BLUETOOTH® DEVICES	5
4.1 Pairing with Mobile phone / TFT systems	5
4.2 Second mobile phone pairing	6
4.3 GPS Pairing	6
5. MOBILE PHONE USAGE	7
5.1 Making and Answering Calls	7
5.2 Siri and Google Assistant.....	7
5.3 Speed Dialing	7
5.3.1 Using preset speed dial numbers.....	7
6. MUSIC	8
6.1 Playing Music with Bluetooth® Devices	8
6.2 Music sharing	8
7. BLUETOOTH® INTERCOM	9
7.1 Intercom pairing	9
7.2 Two-way Intercom Conversation	10
7.3 Multi-user Intercom Conference	10
7.3.1 Starting a Three-way Intercom Conference.....	10
7.3.2 Starting a four-way intercom conference.....	11
7.3.3 Stop Multi-user Intercom.....	11
7.4 Three-Way Conference Phone Call with Intercom Users (with “Advanced Features” activated by APP or Device Manager)	11
7.5 Group Intercom.....	12
7.6 Old Interphone Series	12
7.7 Anycom	12
8. FUNCTION PRIORITY AND FIRMWARE UPGRADES	13
8.1 Function Priority	13
8.2 Firmware Upgrades.....	13
9. CONFIGURATION SETTING	13
9.1 Headset Configuration Setting	13
9.1.1 Delete all pairings.....	13
9.2 Device settings	13
9.2.1 Speed dial.....	14
9.2.2 VOX Phone (Default: Enable)	14
9.2.3 VOX Intercom (Default: Disable)	14
9.2.4 Audio Multitasking (Default: Disabled)	14
9.2.5 HD Voice (Default: Enable).....	14
9.2.6 HD Intercom (Default: Enable)	14
9.2.7 Unit Language.....	14
9.2.8 Voice Prompt (Default: Enable)	14
10. TROUBLESHOOTING	15
10.1 Fault reset.....	15
10.2 Factory reset.....	15

1. ABOUT

1.1 Product details

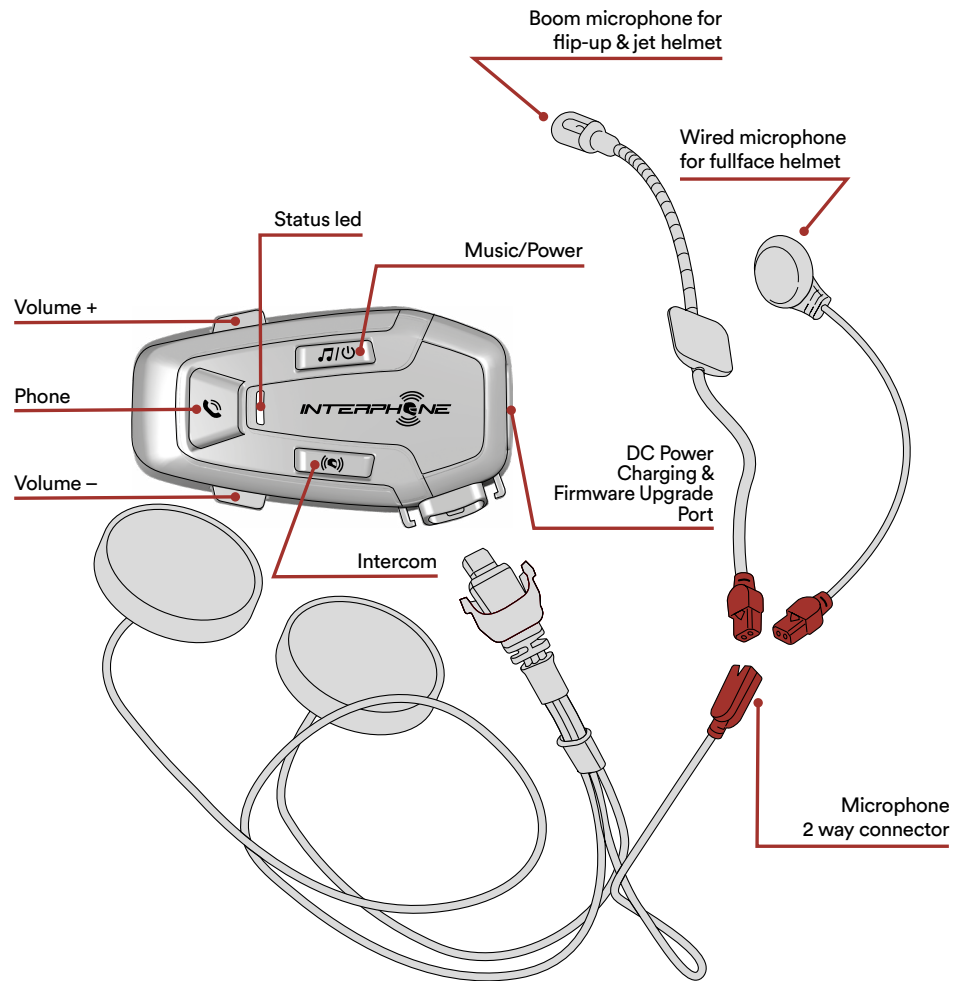

1.2 Package contents

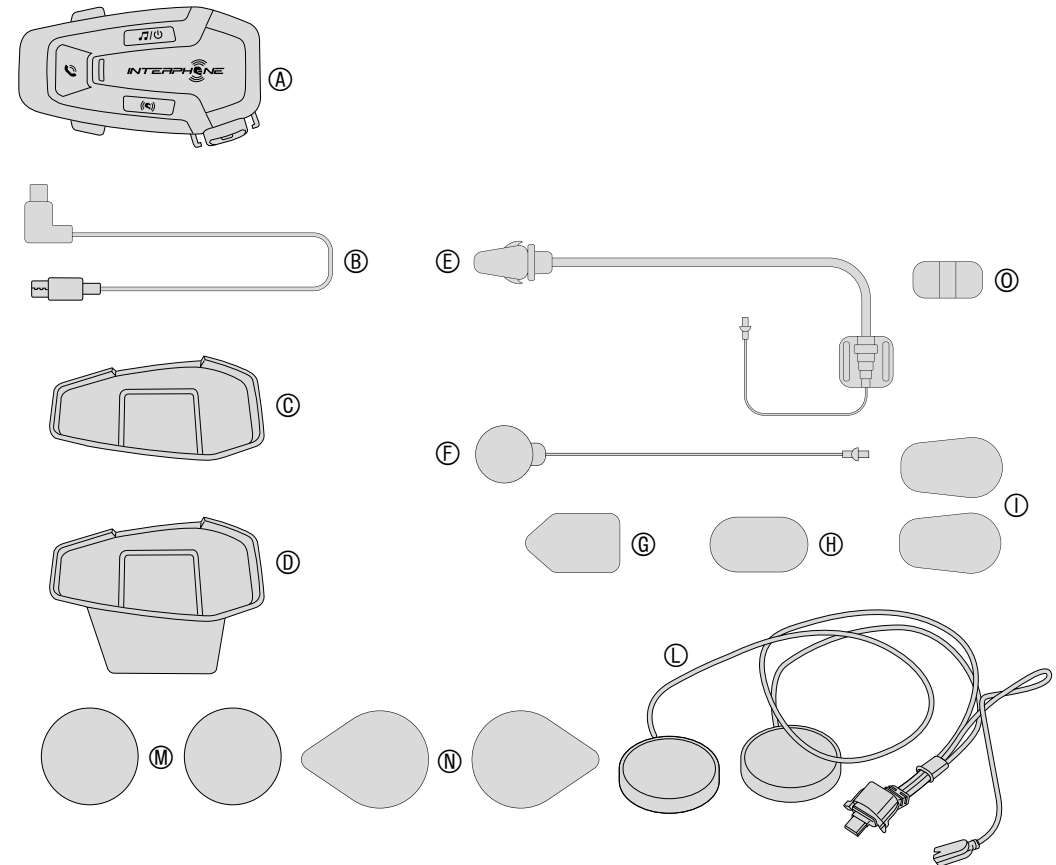

- A) Main unit
- B) Data/charge cable usb type C
- C) Adhesive bracket
- D) Clip-on bracket
- E) Boom microphone
- F) Wired microphone
- G) Boom microphone Velcro
- H) Wired microphone Velcro
- I) Boom microphone foam cover
- L) Speakers
- M) Spacers for speakers
- N) Speakers Velcro
- O) Boom microphone holder

2. HOW TO INSTALL

2.1 Install main unit

Use/application with double-sided adhesive in the bracket

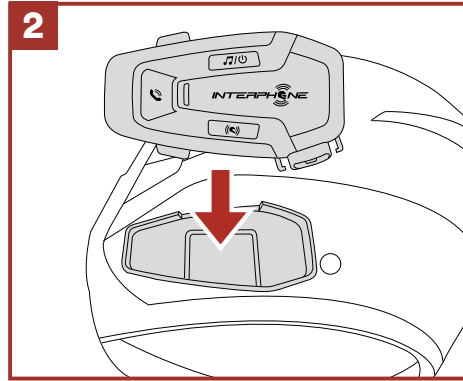
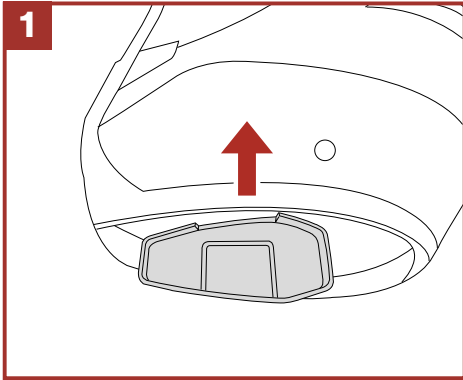

Use/application with the clamp for main unit

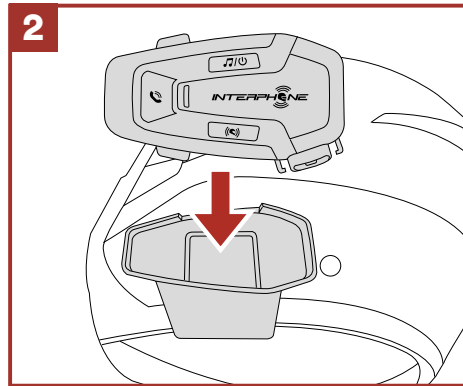
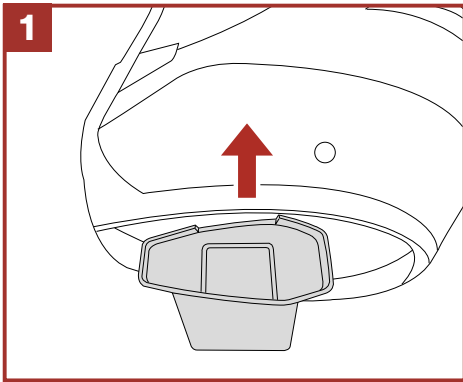

Installing the speakers and the microphone

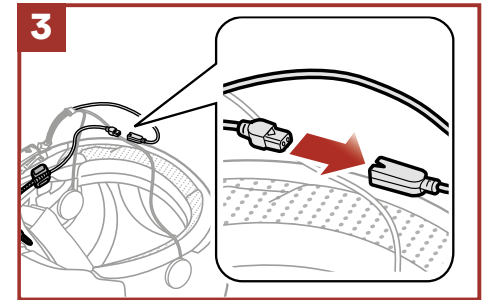
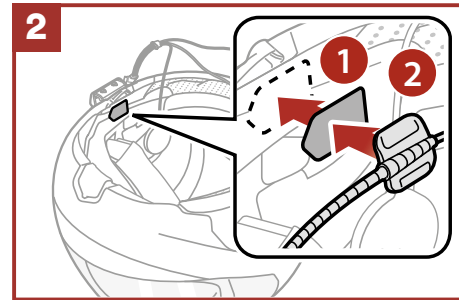
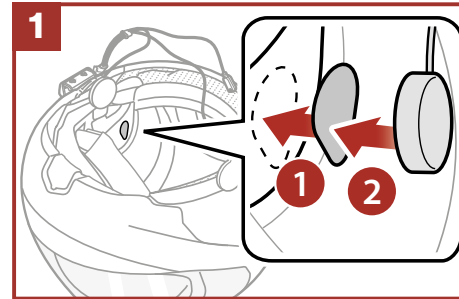

3. GETTING STARTED

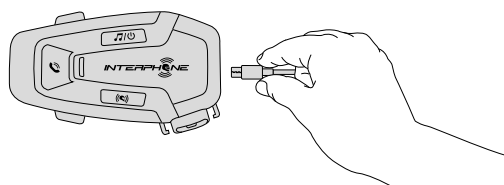
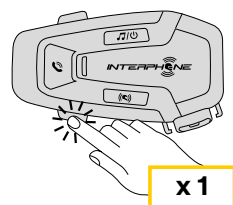
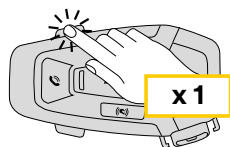
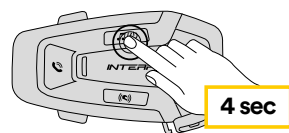
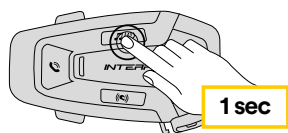
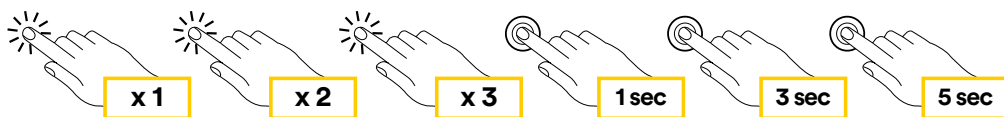

Note:

- Any USB charger with FCC, CE, IC or any local approval can be used.
- U-COM 7R is compatible only with USB device with 5V DC input.

4. PAIRING WITH OTHER BLUETOOTH® DEVICES

When using the headset with other Bluetooth® devices for the first time, they will need to be “paired.” This enables them to recognize and communicate with one another whenever they are within range.

U-COM 7R can be paired to Bluetooth® devices such as mobile phones, GPS Satnav and TFT motorcycle multimedia systems.

4.1 Pairing with Mobile phone / TFT systems

1. Switch on Bluetooth® service on your phone (check device manual for more details).
2. With U-COM 7R on, press and hold INTERCOM button for 5 seconds, to enter settings menu. Don't release the button until the led light is blue.
3. Press once VOLUME + button to start phone pairing mode.
4. On your phone search for new Bluetooth® devices.
5. In few moments the phone will list “U-COM 7R vx.x” among available devices to pair. Select this item.
6. If prompted for a PIN or code, enter 0000 (four times zero).
7. U-COM Voice guide will confirm the successful pairing.
8. If your smartphone asks for additional authorization please confirm.

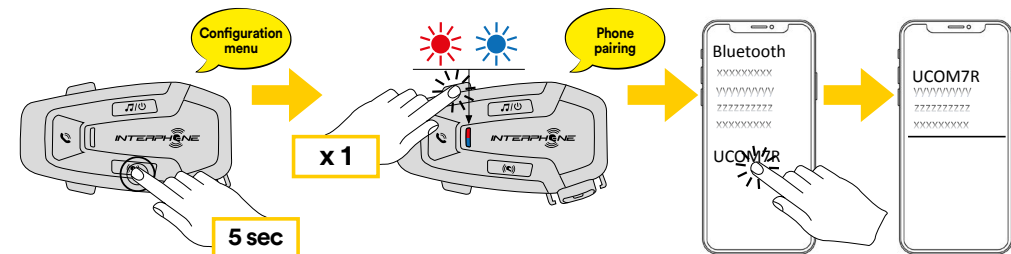

Multimedia TFT system of motorcycle must be paired with “PHONE PAIRING”:

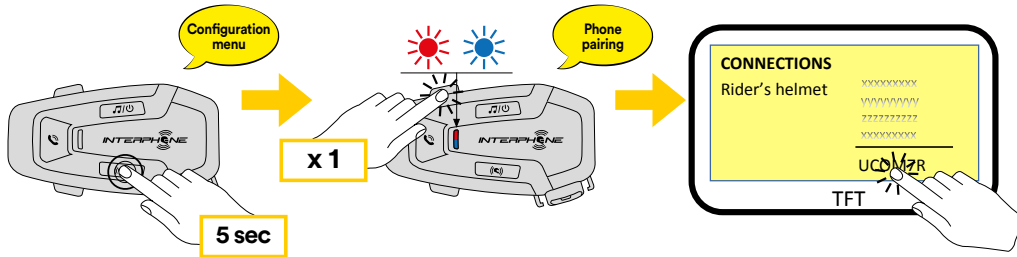

The primary phone will have priority over the second phone, in case of simultaneous call reception on both phones.

4.2 Second mobile phone pairing

1. Switch on Bluetooth® service on your phone (check device manual for more details).
2. With U-COM 7R on, press and hold INTERCOM button for 5 seconds, to enter settings menu. Don't release the button until the led light is blue.
3. Press the VOLUME + button twice to activate Second mobile phone pairing mode.
4. Start the search for new Bluetooth® devices on the mobile phone.
5. In few moments the phone will list “U-COM 7R vx.x” among available devices to pair. Select this item.
6. If prompted for a PIN or code, enter 0000 (four times zero).
7. UCOM Voice guide will confirm the successful pairing.
8. If your smartphone asks for additional authorization please confirm.

4.3 GPS Pairing

1. Switch on Bluetooth® service on your GPS (check device manual for more details).
2. With U-COM 7R on, press and hold INTERCOM button for 5 seconds, to enter settings menu. Don't release the button until the led light is blue.
3. Press the VOLUME + button 3 times to activate GPS pairing mode.
4. Start the search for new Bluetooth® devices on the GPS.
5. In few moments the device will list “U-COM 7R vx.x” among available devices to pair. Select this item.
6. If prompted for a PIN or code, enter 0000 (four times zero).
7. UCOM Voice guide will confirm the successful pairing.
8. If your device asks for additional authorization please confirm.

Gps SATNAV & TFT pairing (to be done with unit on)

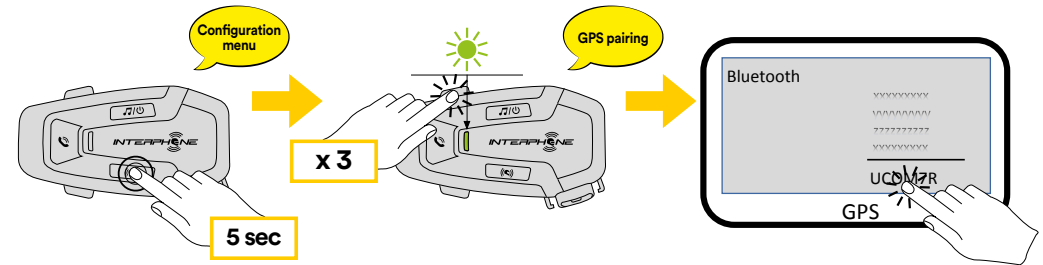

5. MOBILE PHONE USAGE

5.1 Making and Answering Calls

Incoming call answer

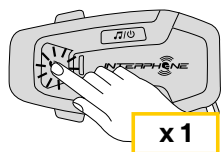

End call



Reject incoming call



Phone assistant trigger

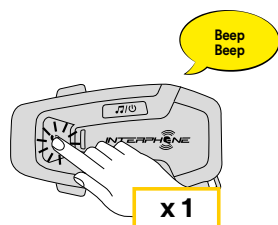

Speed dial



Note: If you have a GPS device connected, you will not hear its voice navigations during a phone call.

5.2 Siri and Google Assistant

U-COM 7R supports the Siri and Google Assistant access directly or press the PHONE button once. You can activate the Siri or Google Assistant using the voice through the headset's microphone, a wake word will be used. This is a word or groups of words such as "Hey Siri" or "Hey Google".

5.3 Speed Dialing

It is possible to store up to 3 telephone numbers (if "advanced mode" is active) to be used as speed dials. You can set the speed dial numbers via UNITE APP or INTERPHONE Device Manager.

5.3.1 Using preset speed dial numbers

How to activate speed dial (with ADVANCED FEATURES off)

Speed dial



How to activate speed dial (with ADVANCED FEATURES on)

1. Enter into the Speed Dial menu.

Speed dial



2. Navigate between the Speed Dial Preset with VOLUME + or VOLUME – buttons, as indicated in picture here below. Select the wanted feature with INTERCOM button.

Select one function	Confirm selected function					
<table border="1"> <tr><td>Last number redial</td></tr> <tr><td>Speed dial #1</td></tr> <tr><td>Speed dial #2</td></tr> <tr><td>Speed dial #3</td></tr> <tr><td>Cancel (exit from menu)</td></tr> </table>	Last number redial	Speed dial #1	Speed dial #2	Speed dial #3	Cancel (exit from menu)	
Last number redial						
Speed dial #1						
Speed dial #2						
Speed dial #3						
Cancel (exit from menu)						

6. MUSIC

6.1 Playing Music with Bluetooth® Devices

Interphone U-COM 7R can play music from Bluetooth® devices (smartphones, MP3 players, Motorcycle TFTs etc ...) equipped with the A2DP profile. To play music you need to pair these devices to INTERPHONE U-COM 7R.

Music play	Music pause
Next track	Previous track

6.2 Music sharing

You can start sharing the music received from your phone with another U-COM control unit, during a two-way intercom conversation.

Both control units can control the playback of music, eg example go to the next track or the previous track.

Note: music sharing cannot be activated at the same time as an intercom conversation.

To start / stop sharing music, activate first the intercom conversation, then press the MUSIC button for 2 seconds (until the second “beep”).

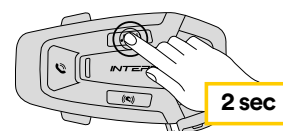

7. BLUETOOTH® INTERCOM

7.1 Intercom pairing

U-COM 7R can be paired with up to 3 other UCOM units (or Sena units), as shown in the following picture.

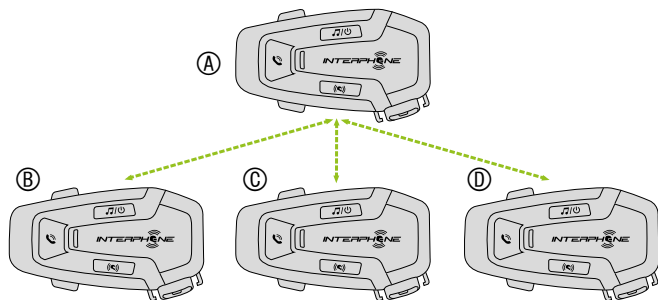

The pairing is only necessary the first time, then the control units will automatically recognize each other.

1. Press and hold the INTERCOM button on both units A and B for 3 seconds, until you hear the voice prompt “intercom pairing”. The light flashing red indicates the device is now visible.

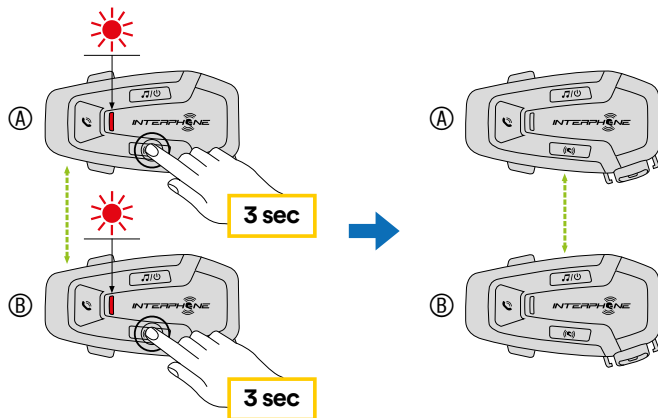

After few seconds the units will be paired and they will start the intercom communication. The light on both units will flash blue twice.

2. Repeat the previous step again, pressing the INTERCOM button on the two units A and C for 3 seconds until you hear the voice prompt “Intercom pairing”.

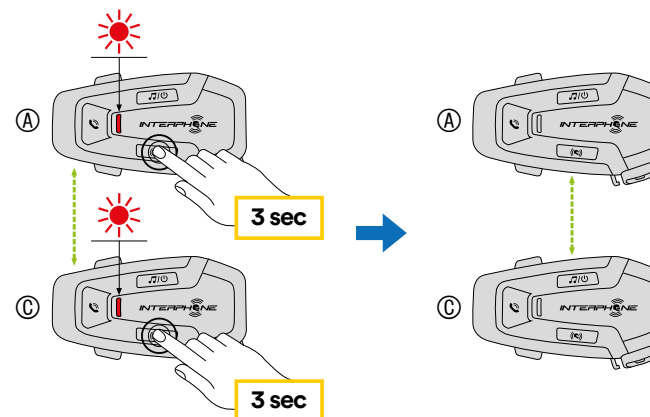

3. Repeat the procedure again, pressing the INTERCOM button of the two units A and D for 3 seconds until you hear the voice prompt “Intercom pairing”.

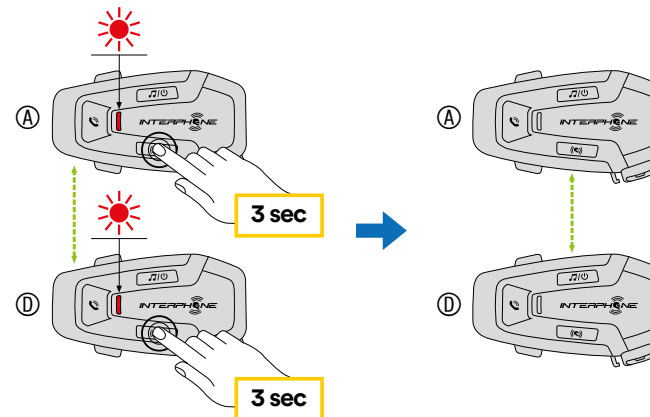

7.2 Two-way Intercom Conversation

After pairing the control units, communication can be started, by pressing the INTERCOM button, according to the diagram below.

1. Press once to connect the control unit D.

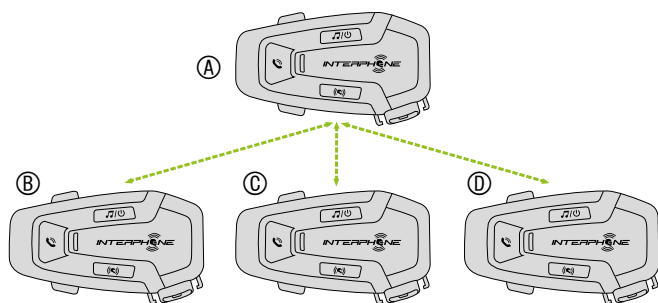

Start/stop intercom connection with unit "D"

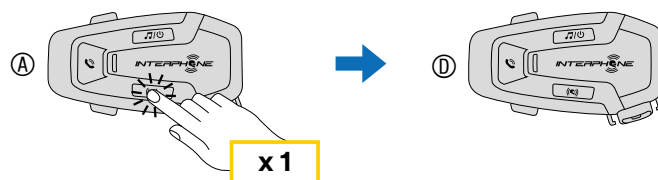

2. Press twice to connect the control unit C.

Start/stop intercom connection with unit "C"

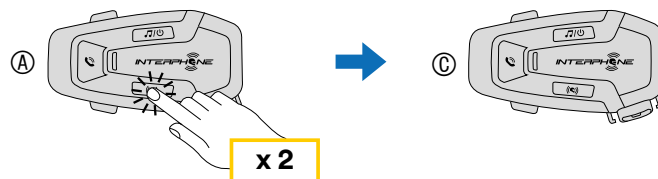

3. Press three times to connect the control unit B.

Start/stop intercom connection with unit "B"

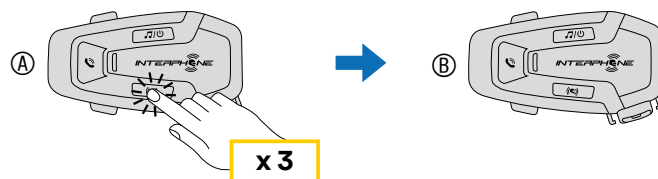

7.3 Multi-user Intercom Conference

Conference conversations can be activated with up to three other units at the same time.

During the three-way or four-way intercom conversation, any mobile phone is temporary disconnected. However, as soon as the conversation ends, the connection with the mobile phone is automatically re-established.

7.3.1 Starting a Three-way Intercom Conference

User (A) can create a three-way intercom conference with two other units (B and C) by establishing two intercom connections at the same time.

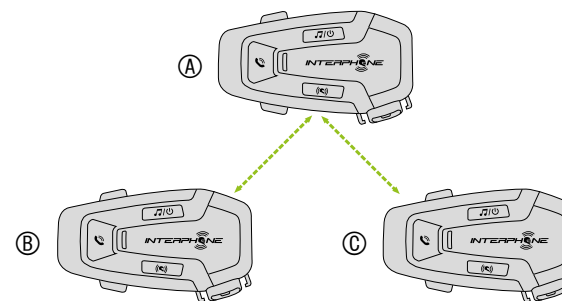

1. Pair the intercom (A) with other two (B and C).
2. Start an intercom conversation with one of the two units in the intercom group. For example (A) can initiate an intercom conversation with (B). Alternatively (B) can initiate an intercom call with (A).

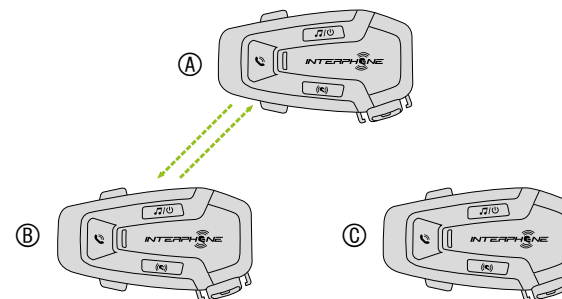

3. Then (A) can call (C), or (C) can join the conversation by making an intercom call to (A).

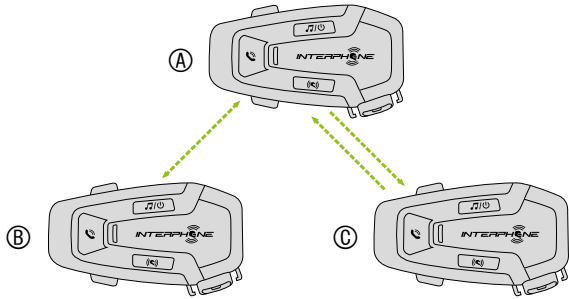

4. Now user (A) and two friends (B and C) will have a three-way intercom conference.

7.3.2 Starting a four-way intercom conference

Pair the first three units A, B, C as indicated in chap. 7.1. Pair D to B or to C. The new participant D can join the other three previously connected friends, creating a four-way conference, making an intercom call to B or C.

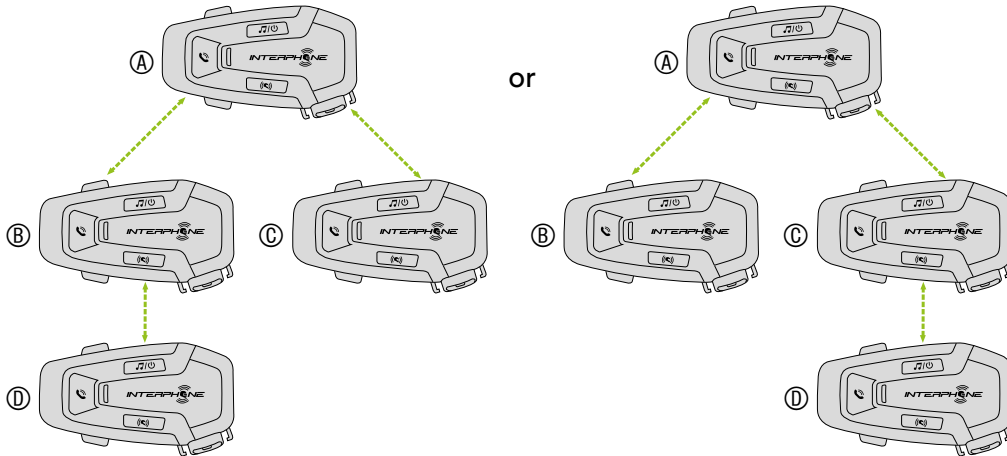

7.3.3 Stop Multi-user Intercom

To stop all intercom connections, press and hold the INTERCOM button for 2 seconds until the beep.

7.4 Three-Way Conference Phone Call with Intercom Users (with “Advanced Features” activated by APP or Device Manager)

You can have a three-way Conference-Phone Call by adding an intercom user to the mobile phone conversation.

During a mobile phone call, tap the INTERCOM button once, twice or three times, to invite one of the intercom units (previously paired) to the conversation.

Press once to add unit D to the conference.

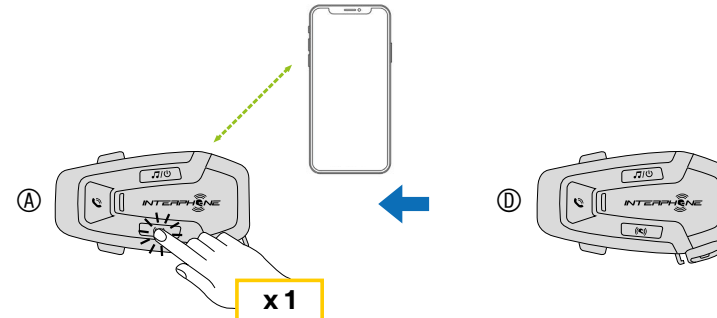

Press twice to add unit C to the conference.

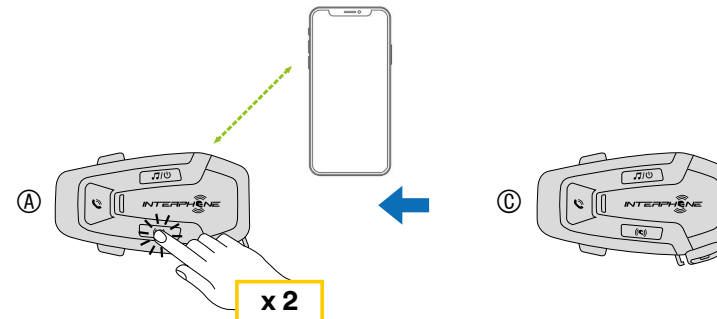

Press three times to add unit B to the conference.

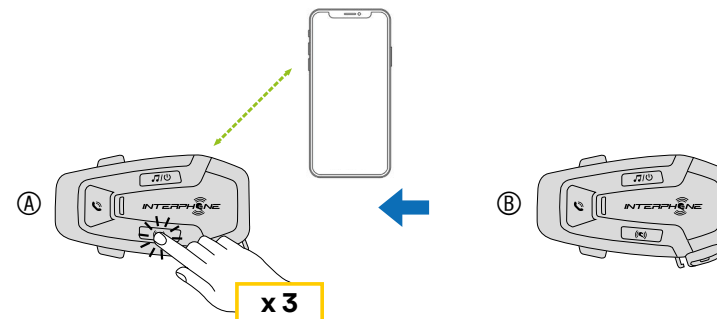

Repeat the same command to disconnect intercom unit from the phonecall conference.

To disconnect the mobile phone call during a conference phone call, press and hold the INTERCOM button for 1 second.

Note: When you have an incoming intercom call during a mobile phone call, you will hear high tone double beeps.

7.5 Group Intercom

Group Intercom is a command that allows you to instantly start a Multi-Way Conference Intercom with three of the most recently paired headsets.

The first unit is the one which will activate the connection of all the members of the group.

Connection will be established with same logic of normal 4 way conference.

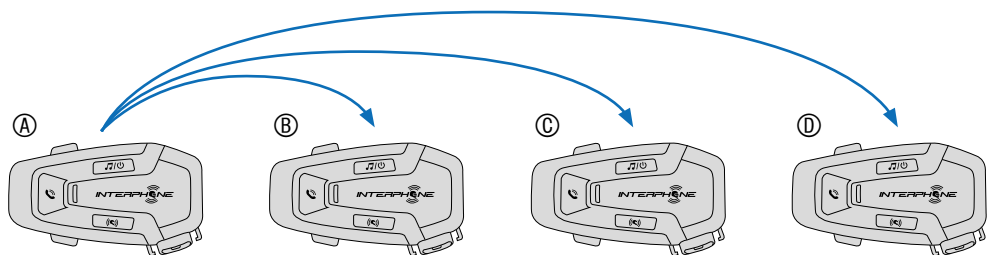

1. Go through intercom pairing with up to three headsets you want to have Group Intercom with.
2. Tap the VOLUME + and VOLUME – buttons together to begin Group Intercom. The LED will flash green and you will hear a voice prompt, “Group intercom”.

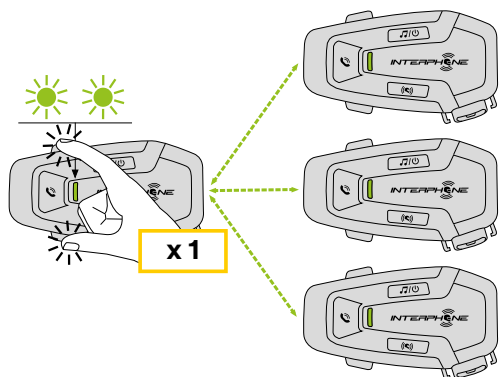

3. When all of the headsets are connected together, everyone will hear a voice prompt, “Group intercom connected”.
4. To stop Group Intercom, press and hold the INTERCOM button for 1 second during Group Intercom. You will hear a voice prompt, “Group intercom terminated”.

7.6 Old Interphone Series

It is possible to pair previous Interphone series devices by pressing, with the unit on, the INTERCOM and TELEPHONE buttons for 3 seconds. Then start pairing mode on the second unit, usually pressing the power button (with the control unit off) until the led flashes red/blue.

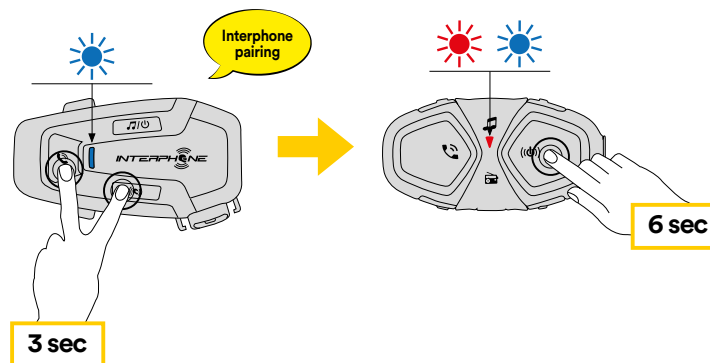

7.7 Anycom

Anycom feature allows intercom conversations with other intercom brands. It is possible to pair the intercom with only one non-Interphone device at a time. The intercom distance depends on the performance of the connected Bluetooth® intercom. When a not-Interphone device is paired with the Interphone device, if another Bluetooth® device is paired via the second mobile phone pairing, it will be disconnected.

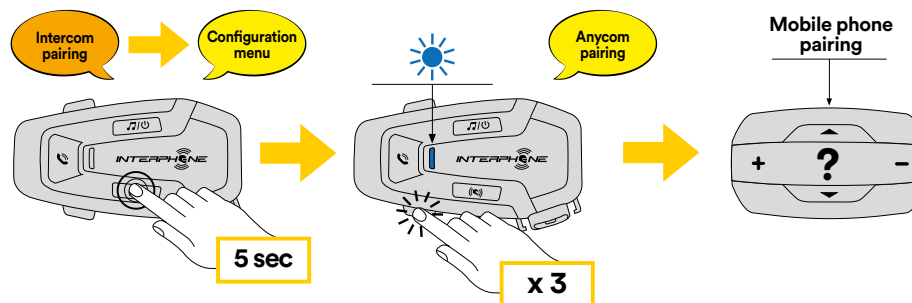

1. With U-COM 7R on, enter the configuration menu by pressing the INTERCOM button for 5 seconds. Do not to release the button before the led turns blue.
2. Press the VOLUME – button 3 times to activate the ANYCOM pairing mode.
3. Set the not-Interphone intercom to mode Phone pairing.

8. FUNCTION PRIORITY AND FIRMWARE UPGRADES

8.1 Function Priority

The headset prioritizes connected devices in the following order:

1. (Highest) Mobile phone
2. Bluetooth® Intercom
3. (Lower) Bluetooth® stereo music

Priority between intercom and music can be changed via the APP Interphone unite or the Device Manager for Win/MAC.

A lower-priority function gets interrupted by a higher-priority function. For example, stereo music will be interrupted by an Bluetooth® Intercom Conversation; an Bluetooth® Intercom Conversation will be interrupted by an incoming mobile phone call.

8.2 Firmware Upgrades

The headset supports firmware upgrades. Using the Device Manager utility (available for PC and MAC on www.interphone.com) you can upgrade firmware.

The USB Power & Data Cable (USB-C) must be connected to your computer, then start Device Manager on computer and follow instructions step by step.

Interphone Unite APP can check the firmware version present on the headset and inform you in case of a newer available firmware, but APP can't flash the new firmware to headset.

9. CONFIGURATION SETTING

9.1 Headset Configuration Setting

With U-COM 7R on, press and hold INTERCOM button for 5 seconds, to enter settings menu. Don't release the button until the led light is blue.

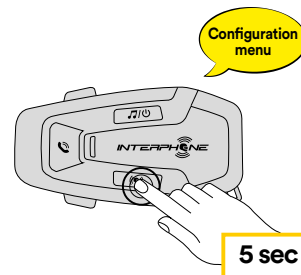

To navigate through the settings, press once the VOLUME + button or the VOLUME – button.

1. Phone pairing
2. Second Mobile Phone Pairing
3. GPS pairing

To confirm the following configuration menu options, press INTERCOM button once.

4. Delete all pairings
5. Anycom pairing
6. Factory reset
7. Exit

9.1.1 Delete all pairings

Delete all Bluetooth® pairings stored in the device.

9.2 Device settings

You can change the device settings from the Device Manager utility (available for PC and MAC on www.interphone.com) or from the Interphone UNITE app.

Attention: the setting "Advanced Features" will enable the following headset features:

- Phone multiple speed dial

9.2.1 Speed dial

Assign phone numbers for speed dialing to make a phone call quickly.

9.2.2 VOX Phone (Default: Enable)

If this feature is enabled, you can answer incoming calls by voice. When you hear a ringtone for an incoming call, you can answer the phone by saying a word such as “Hello” loudly or by blowing air into the microphone. VOX phone is temporarily disabled if you are connected to intercom. If this feature is disabled, you have to tap the PHONE button to answer an incoming call.

9.2.3 VOX Intercom (Default: Disable)

If VOX Intercom is enabled, you can initiate an intercom conversation with the last connected intercom by voice. When you want to start intercom, say a word such as “Hello” loudly or blow air into the microphone. If you start an intercom conversation by voice, the intercom terminates automatically when you and your intercom friend remain silent for 20 seconds. However, if you manually start an intercom conversation by tapping the INTERCOM button, you have to terminate the intercom conversation manually. However, if you start the intercom by voice and end it manually by tapping the INTERCOM button, you will not be able to start intercom by voice temporarily. In this case, you have to tap the INTERCOM button to restart the intercom. This is to prevent repeated unintentional intercom connections by strong wind noise. After rebooting the headset, you can start the intercom by voice again.

9.2.4 Audio Multitasking (Default: Disabled)

Audio Multitasking (Bluetooth® Intercom Audio Multitasking) allows you to have an intercom conversation while simultaneously listening to music or GPS instructions. The overlaid audio is played in the background with reduced volume whenever there is an intercom conversation and will return to normal volume once the conversation is finished.

Note:

- For Bluetooth® Intercom Audio Multitasking to work properly, you need to power the headset off and on. Please restart the headset.
- Bluetooth® Intercom Audio Multitasking will be activated during two-way intercom conversations with a headset that also supports this feature.
- Some GPS devices may not support this feature.
- The Audio Multitasking feature can be configured through the Intercom-Audio Overlay Sensitivity and the Audio Overlay Volume Management settings.
- Attention, activating Audio Multitasking will lead to a deterioration of the quality of the Intercom audio.

9.2.5 HD Voice (Default: Enable)

HD Voice allows you to communicate in high-definition during phone calls. This feature increases the quality so that the audio will be crisp and clear during phone call conversations.

Three-Way Conference Phone Call with Intercom Participant will not be available if HD Voice is enabled.

Note:

- Refer to the manufacturer of your Bluetooth® device that will be connected to the headset to see if it supports HD Voice.
- HD Voice is active only when Bluetooth® Intercom Audio Multitasking is disabled.

9.2.6 HD Intercom (Default: Enable)

HD Intercom enhances the two-way intercom audio from normal quality to HD quality. HD Intercom will become temporarily disabled when you enter into a multi-way intercom. If this feature is disabled, the two-way intercom audio will change to normal quality.

Note:

- The intercom distance of HD Intercom is relatively shorter than normal intercom.
- HD Intercom will become disabled temporarily when Bluetooth® Intercom Audio Multitasking is enabled.

9.2.7 Unit Language

You can select the device language. The selected language is maintained even when the headset is rebooted

9.2.8 Voice Prompt (Default: Enable)

You can disable voice prompts by software configuration settings, but the following voice prompts are always on.
- Headset configuration settings menu, battery level indicator, speed dial.

10. TROUBLESHOOTING

Please visit www.interphone.com for video tutorials and answers to frequently asked questions.

10.1 Fault reset

When the intercom does not work properly, it is possible to reset the unit easily, by inserting a paper clip inside the reset hole, on the back of the main unit and pressing gently.

Note: Reset after error will not restore the intercom to factory settings.

10.2 Factory reset

To erase all of your settings and start fresh, the headset can be restored to factory default settings using the Factory Reset feature.

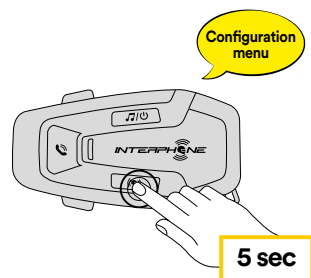

With U-COM 7R on, enter the configuration menu by pressing INTERCOM button for 5 seconds. Be careful not to release the button before the LED turns blue, you will hear the message confirming activation of the configuration menu.

Press the VOLUME – button twice until you hear the message “Factory reset”, press once the INTERCOM button to confirm. A voice announcement will be issued to confirm: "Reset headphones, goodbye".